

# Mokveld

---



## surge relief valves

---

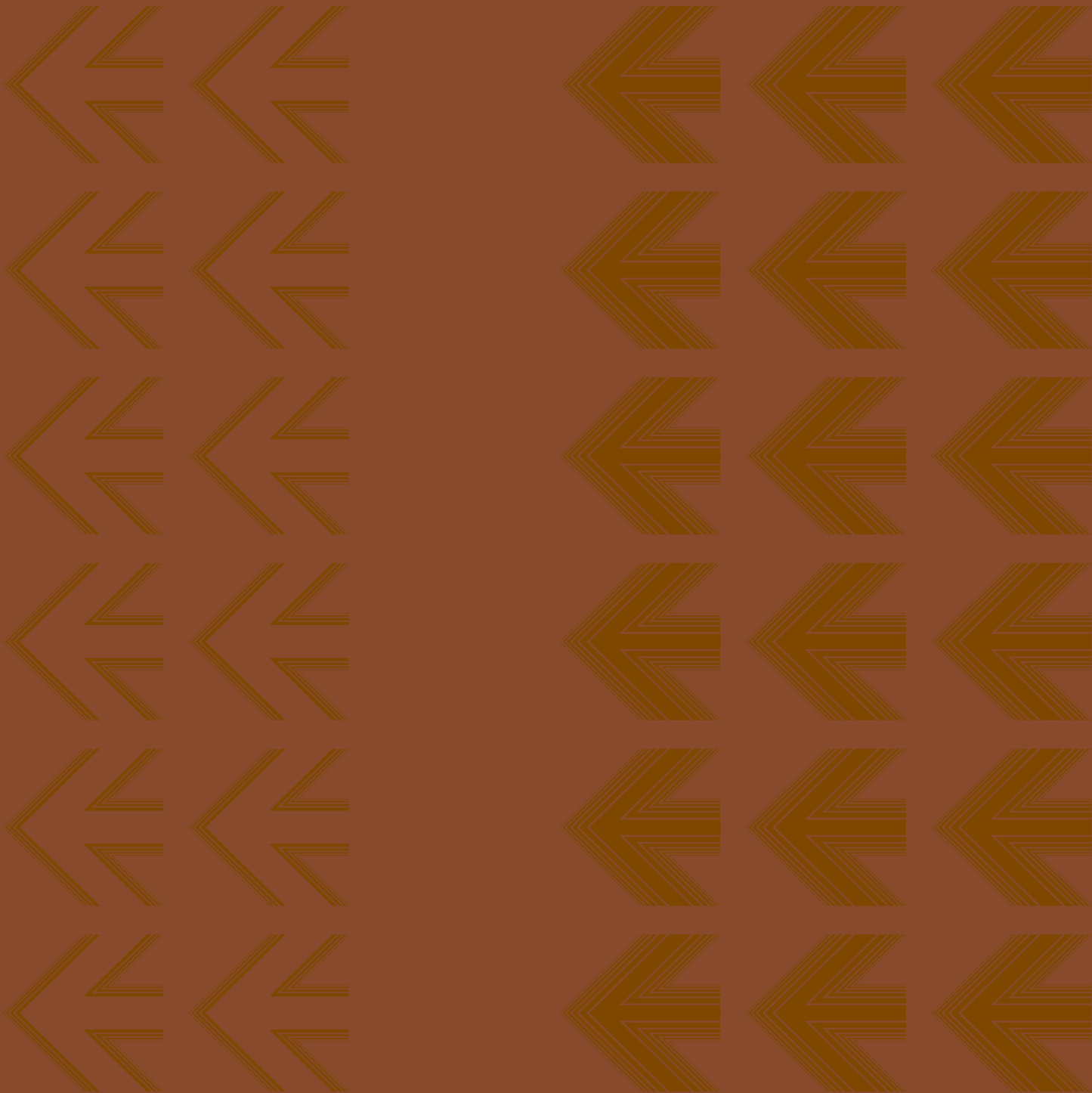



# Mokveld pilot operated surge relief valves a concept that works

---

As in other Mokveld products the design of the Mokveld self acting surge relief valve is based on the axial flow concept.

'Axial flow' describes the in-line symmetrical flow path between the valve inner body and outer body before the flow reaches the trim zone.

The axial flow concept, used for decades by Mokveld in their design for shut off, control and check valves, has proven to be so advantageous that it could easily be incorporated in the design of a surge relief valve.

In order to develop reliable devices, designs have to be based on simplicity. This has been achieved in the design of the Mokveld self acting surge relief valve.

Mokveld valves typically make use of this philosophy by implementing a minimum of components in their design of surge relief valves. This is extremely advantageous, impacting directly and positively both on reliability and maintenance. Related costs are also correspondingly lower.

A pressure surge is generated in a pipeline system when there is a change in the rate of flow in the system. The surge pressure can be dangerously high if the change is too rapid.

Surge pressures, moving along the pipe line with the speed of sound, vary in their magnitude.

The Mokveld surge relief valve, because of its axial flow and thus stable opening behaviour, its pilot design and consequently high effective capacity, allows the valve to fully protect the piping systems against dangerous and costly surge pressure damages.

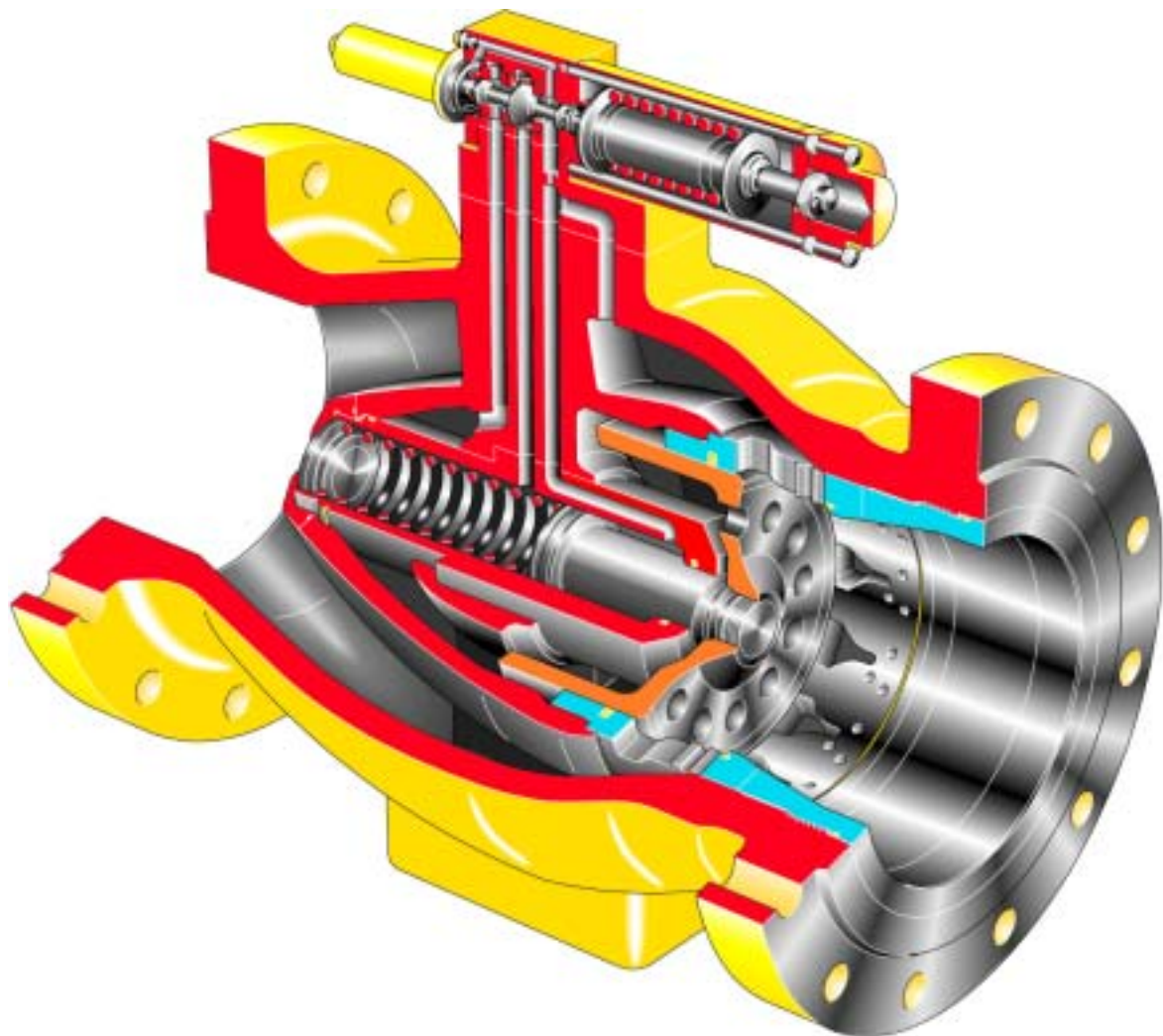

# the surge relief valve that offers more

---

## high available capacity

Because of the high effective valve capacity, a result of the linear response of the pilot valve, sizes are smaller compared to those of competitors. Extreme oversizing is not required.

## quick response time

The proportional pilot design is of a high capacity, allowing fast response of the surge relief valve.

## low tolerance of set pressure

As a result of the pilot design the overpressure can be limited to 1% of the set pressure.

## no external energy; no nitrogen consumption

The use of the pilot type design eliminates the nitrogen back-up including temperature compensation devices.

## simple installation layout

Because of the absence of a nitrogen system, the main reason for skid mounting is eliminated.

## high performance

Pilot and surge valve design are based on simplicity. All components are field proven to provide maximum reliability to protect your system.

## stable operation

Because of the cage trim, the opening behaviour remains stable and predictable at each differential pressure.

## anti-cavitation trims available

Optional trim types are available eliminating cavitation and vibration to downstream piping.

# principle of operation

---

The Mokveld surge relief valve is engineered to quickly measure unabated surge pressures, then to open fast to relief and close, without slamming, into seating.

The operation of the surge relief valve is simple, since only the liquid pressure is used to open and close the valve.

The pressure of the liquid is directly connected to the right chamber as well as ported via the pilot to the left chamber of the internal cylinder of the valve.

In normal situations, the valve is seated (forced to close) because of a resulting force generated through the larger effective area of the left chamber.

---

If the upstream pipeline pressure exceeds the set-point pressure of the pilot, (i.e. adjustable at the pilot) the pilot will change position and will connect the low downstream pressure to the left chamber of the internal valve cylinder. The resulting force will move the internal plunger and consequently the valve piston to open and relieving will start via the seat zone, allowing upstream pipeline pressure to drop. Once the pilot's set-point has been reached, the valve will open proportionally on higher pressures, controlling the inlet pressure with an accuracy of 1%.

The closing cycle is vice versa but dampened to avoid slamming.

---

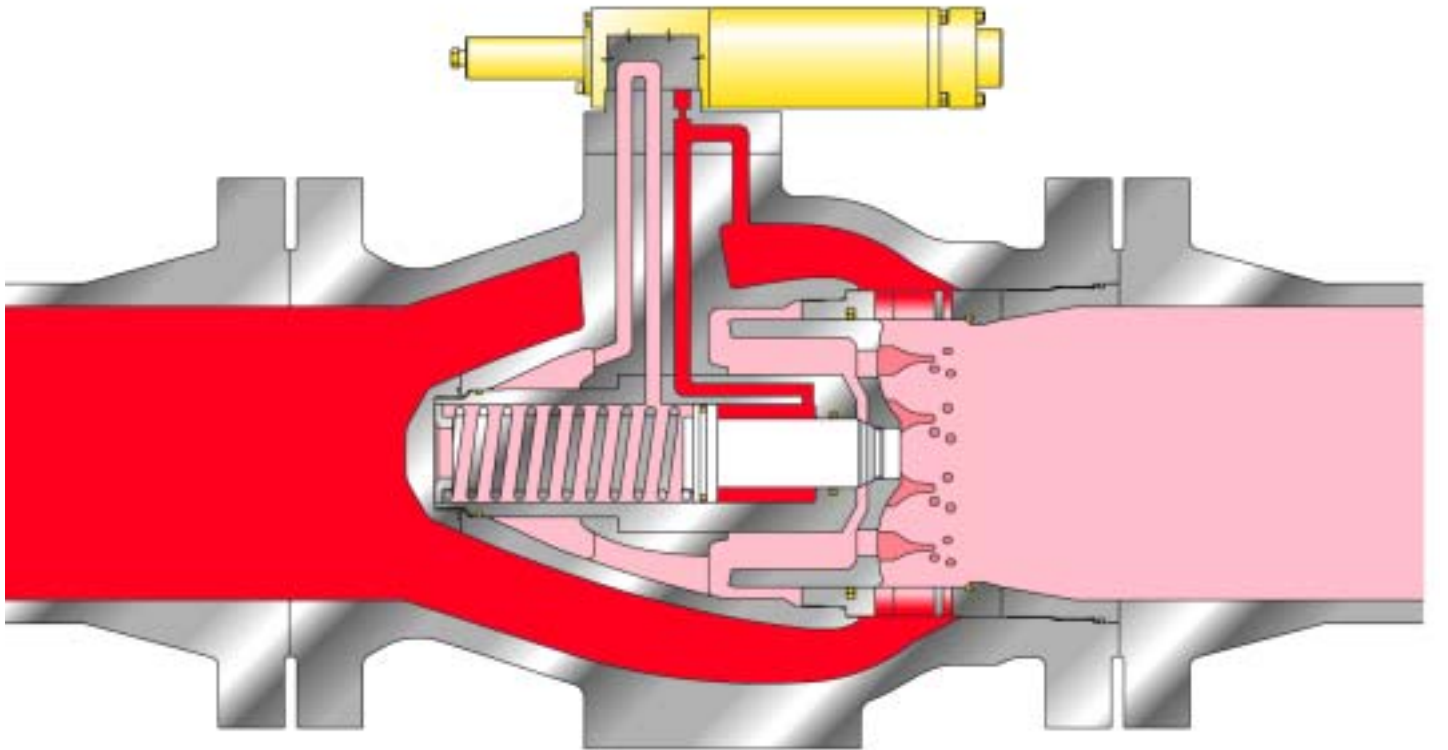
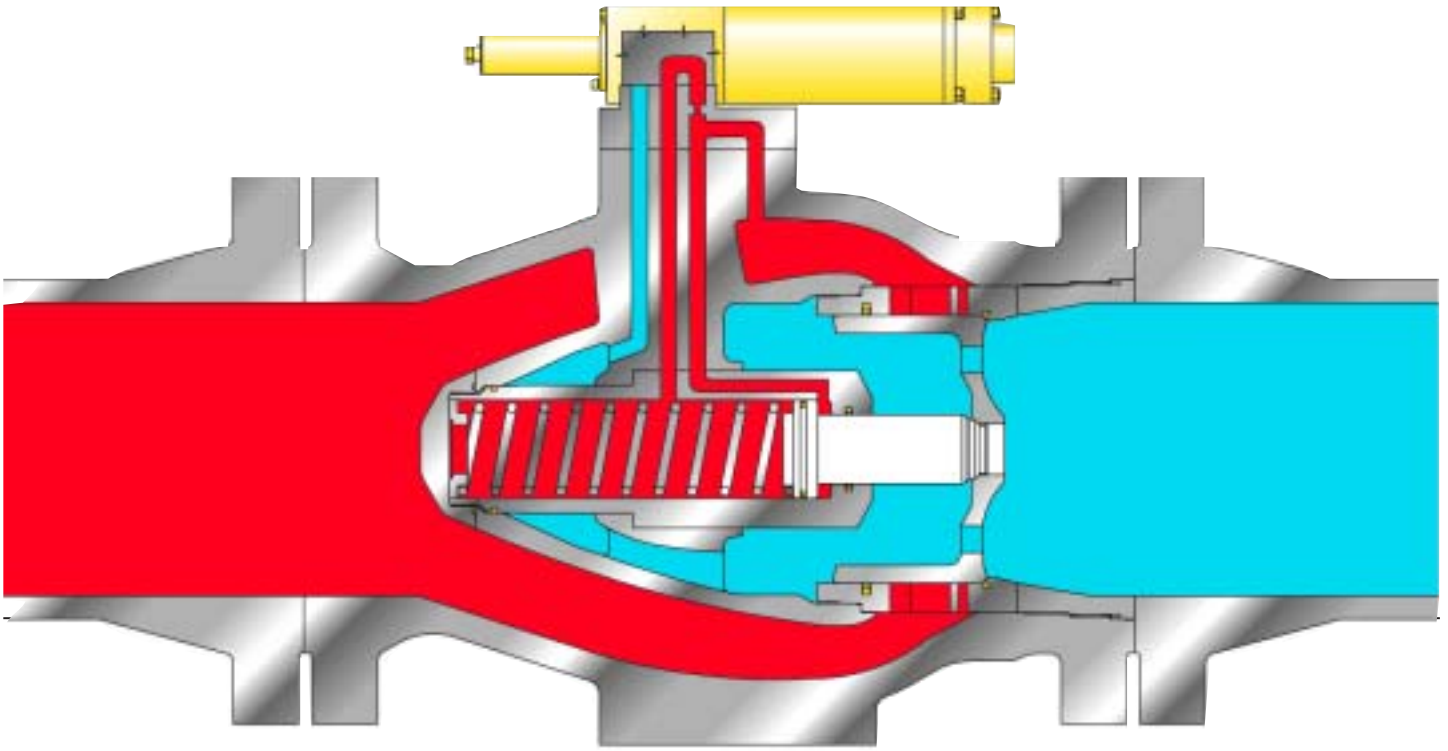

# sizing and maintenance

## sizing

The Mokveld axial-flow surge relief valve is equipped with a trim cage. A wide selection of trims is available including multi-stage anti-cavitation styles.

Please advise the Mokveld design engineers on flow conditions for calculation of the most suitable valve size and trim.

These trims are based on well-proven designs which have been widely used in Mokveld control valves.

The design of the trim will counteract unbalanced forces. Opening behaviour is therefore stable.

## pilot assembly

The pilot is a Mokveld designed reliable 3-way, 2 position type. Special attention has been given to low hysteresis and this is obtained by using friction free metal bellows instead of O-rings.

The use of bellows will furthermore eliminate failures as a result of debris in the fluid.

The pilot unit is directly bolted on top of the valve, to maintain full integrity of the pilot system with the valve.

## valve maintenance

Due to the absence of nitrogen, possible valve failure because of rubber tube splits, non possibility of spring failure etc., the need for any specific attention and maintenance during normal operation is eliminated.

As there is a minimum of moving parts, employment of PTFE seals and the installation of friction-free bellows in the pilot, the risk of valve failure is minimized.

Please note also that the pilot is not easily affected by dirt. However when used in high sand loaded media or used in crude fluids containing wax,

a seal pot can be installed between the pressure intake and the pilot sensor. All this leads to an expected time between inspection or maintenance of at least five (5) years. Mokveld advises testing of the valve/pilot operation to be done at regular intervals, using the testing connection on the valve.

## response time

Although time responses vary in each application, the surge relief valve always responds rapidly and very smoothly. Typical response times of Mokveld surge relief valves are milliseconds to full capacity.

The valve closes in direct response to the pressure decay at valve inlet. Closing times are adjustable between 3 and 40 seconds.

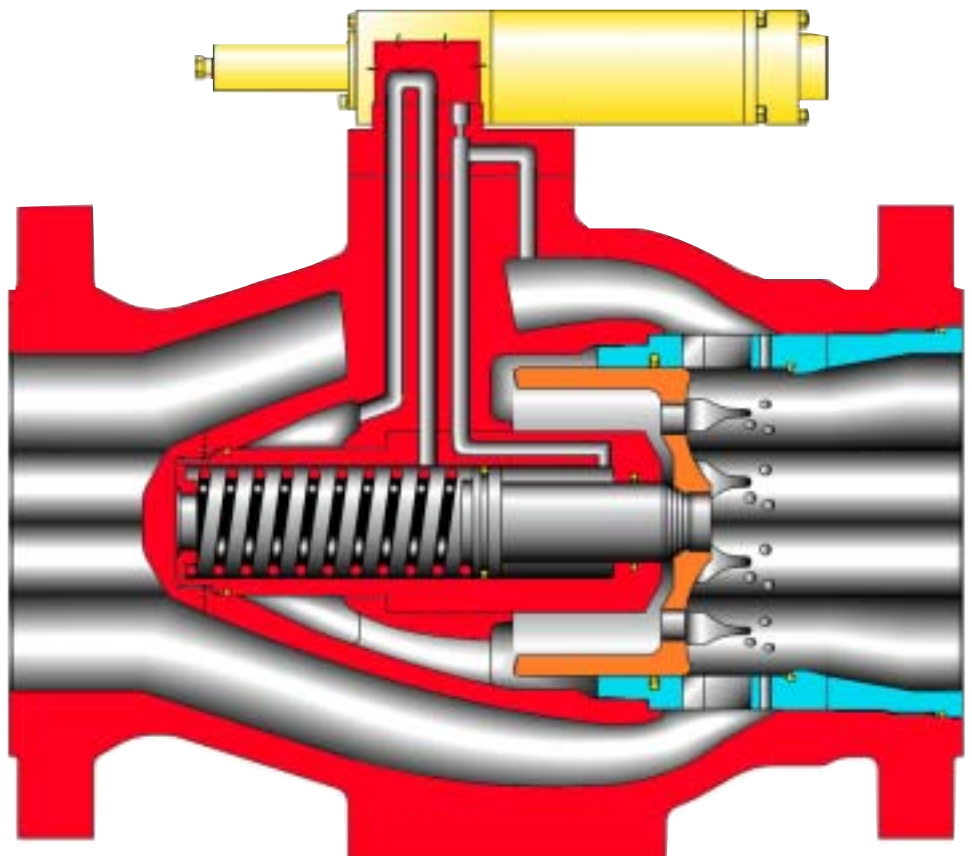



# other Mokveld products

---

**Mokveld Valves is manufacturer of:**

- control valves
- shut-off valves
- surge relief valves
- choke valves
- check valves
- actuators and control systems

Separate brochures are available upon request.

*anti-surge control valve 12" ANSI 600,  
compressor station Russia*

*flowline shut-off valves  
gas production plant,  
N/E Netherlands  
(by courtesy of NAM)*



# other Mokveld products

*adjustable choke valves 7<sup>1</sup>/<sub>16</sub>"  
API 10,000 with inconel cladding,  
gas production field UAE*



*adjustable choke valves 8" ANSI 900 lbs  
with pneumatic actuators,  
gas production offshore Malaysia*

*surge control valves 20" and 24"  
ANSI 300 lbs,  
gas compression facility New Mexico*



# other Mokveld products

---



*inline production chokes 10" ANSI 1500,  
FPSO Norway*



*pressure control valves 20" ANSI 600 lbs and safety slam shut valves  
16" ANSI 600 lbs, M & R station Germany*

*flow control valves, underground gasstorage field Germany*



*safety shut-off valve 16" ANSI 600,  
underground storage field Germany*

# other Mokveld products

---



*shut-off valves and non-slam check valves  
6" ANSI 900 lbs, water injection manifold  
of a crude oil production field, North Africa*



*flow pressure control valves and safety shut-off  
valves, M & R station Germany*





# Mokveld Valves

---



**Mokveld Valves bv**

P.O. Box 227  
2800 AE Gouda Holland  
Nijverheidsstraat 67  
telephone (31) 182 597500  
facsimile (31) 182 517977  
mokveld@mokveld.com  
www.mokveld.com

---

**Mokveld offices in:**

Houston, United States of America  
Wesel, Germany  
Swindon, United Kingdom  
Dubai, United Arab Emirates  
Sumy, Ukraine  
Beijing, the People's Republic of China  
Kuala Lumpur, Malaysia  
Stavanger, Norway